

Energy efficiency of conventional air conditioning systems in light of climate change

Eng. Fawaz Khaled Ghaith

PAAET | Kuwait

Received:

29/12/2022

Revised:

10/01/2023

Accepted:

05/02/2023

Published:

30/03/2023

* Corresponding author:

www.s3a3@ymail.com

Citation: Ghaith, F. K.

(2023). Energy efficiency

of conventional air

conditioning systems in

light of climate change.

Journal of engineering

sciences and information

technology, 7(1), 80 – 94.

[https://doi.org/10.26389/](https://doi.org/10.26389/AJSRP.G291222)

[AJSRP.G291222](https://doi.org/10.26389/AJSRP.G291222)

2023 © AJSRP • National

Research Center, Palestine,

all rights reserved.

• Open Access



This article is an open

access article distributed

under the terms and

conditions of the Creative

Commons Attribution (CC

BY-NC) [license](https://creativecommons.org/licenses/by-nc/4.0/)

Abstract: The energy used in a country's economy is very important to its development. Over the years, the electricity and ventilation consumption of buildings have increased. People's concerns about the quality of their indoor environment are also increasing. Most buildings have air conditioning and ventilation systems that are designed to provide an environment that's comfortable and healthy for the occupants. This is done through the use of ventilation. In addition to improving the indoor air quality, it can also help prevent people from experiencing discomfort.

Studies have shown that about 60% of office buildings' energy consumption is attributed to the use of air conditioning systems. These systems provide cool air to the spaces while keeping the temperature controlled.

A VAV system can meet the health criterion and the IAQ by supplying enough fresh air to meet national standards. A conventional AC system requires a refrigeration plant and a network of pipes to deliver cold water to the spaces.

Since air-cooled chiller systems have a flexible design, they are commonly used in commercial buildings. They can provide a cooling effect that's significantly higher than that of water-cooled units. Compared to water cooling systems, air-cooled units are more energy-efficient. This is because the head pressure control of the system ensures that the pressure is kept high.

The use of air conditioning has been one of the biggest sources of electrical energy consumption worldwide. It has contributed over 10% of the total energy produced, and it contributes to the harmful effects of climate change. Climate change is a growing concern that will require the production and use of more air conditioning units. This has necessitated the development of a comprehensive research to address this issue.

Keywords: Air Conditioning , Energy ,Efficiency, climate change, VAV

كفاءة الطاقة لأنظمة التكييف التقليدية في ظل تغير المناخ

م. فواز خالد غيث

الهيئة العامة للتعليم التطبيقي والتدريب | الكويت

المستخلص: الطاقة المستخدمة في اقتصاد بلد ما مهمة جدا لتنميته، على مر السنين ، زاد استهلاك الكهرباء باستخدام المكيفات للمباني. كما تتزايد مخاوف الناس بشأن جودة بيئتهم الداخلية. تحتوي معظم المباني على أنظمة تكييف وتهوية مصممة لتوفير بيئة مريحة وصحية. أظهرت الدراسات أن حوالي 60٪ من استهلاك الطاقة في مباني المكاتب يعزى إلى استخدام أنظمة تكييف الهواء. توفر هذه الأنظمة هواء باردا للمساحات مع الحفاظ على التحكم في درجة الحرارة.

يمكن لنظام VAV تلبية المعايير من خلال توفير ما يكفي من الهواء النقي لتلبية المعايير الوطنية. يتطلب نظام التكييف التقليدي محطة تبريد وشبكة من الأنابيب لتوصيل الماء البارد إلى المساحات. نظرا لأن أنظمة التبريد المبردة بالهواء لها تصميم مرن ، فإنها تستخدم بشكل شائع في المباني التجارية. يمكن أن توفر تأثير تبريد أعلى بكثير من تأثير الوحدات المبردة بالماء. بالمقارنة مع أنظمة تبريد المياه ، فإن الوحدات المبردة بالهواء أكثر كفاءة في استخدام الطاقة. وذلك لأن أساس عملية التحكم في الضغط للنظام يضمن الحفاظ على الضغط مرتفعا.

كان استخدام تكييف الهواء أحد أكبر مصادر استهلاك الطاقة الكهربائية في جميع أنحاء العالم. انها تستهلك أكثر من 10٪ من إجمالي الطاقة المنتجة ، وتساهم في الآثار الضارة لتغير المناخ. تغير المناخ هو مصدر قلق متزايد يتطلب إنتاج واستخدام المزيد من وحدات تكييف الهواء. وقد استلزم ذلك تطوير بحث شامل لمعالجة هذه المسألة. الكلمات المفتاحية: تكييف الهواء ، الطاقة ، الكفاءة ، تغير المناخ.

Introduction

The concept of energy efficiency is a major area of research that is expected to be pursued in the coming years due to the increasing economic and environmental concerns. In particular, the development of new buildings has been a major contributor to the energy consumption of buildings (Andrade et al., 2021). The IEA released a report in 2018 that warned about the potential of space cooling issues. It noted that the energy used for this type of cooling has increased significantly over the last two decades. This is putting a strain on the electricity systems in several countries, such as Egypt.

In order to minimize the impact of space cooling on the electricity grid, various policies and programs need to be implemented. An assessment conducted in Egypt revealed that the air conditioning units in commercial buildings consume up to 75% of the energy used. Following the energy crisis of the 1970s, various countries have started to improve the energy labelling of commercial buildings. These efforts have provided both environmental and financial benefits (C. Munaaim et al., 2017). However, Egypt is still yet to implement building regulations related to this subject.

The five levels of energy efficiency are based on the building envelope, air conditioning system, lighting system, and the building's overall design. The energy consumption of commercial air conditioning units can be classified based on a combination of factors, such as the building's size and the standards for its operation. For instance, according to the ASHRAE standard 90.1 standard, the efficiency of a central air conditioning system should be based on the measurements of the COP and the IPLV (Yuan et al., 2011).

A simulation method is used to compare two different models, namely the reference building and the real/proposed one. These two models should have the same characteristics, such as having the same set point temperature and air conditioning system type. According to ISO 5151, which was released in 2017, the energy efficiency of a commercial air conditioning system is measured based on the conditions under which it operates. But, there are no standards for certain types of equipment, such as VRF and chillers (Ni & Bai, 2017).

In Egypt, the regulation adopted the System Part-Load Value (SPLV), which is a measure of the efficiency of a building's air conditioning system. This is a representation of the system's performance under certain conditions. The system part-load value is computed by taking into account the annual thermal load, as well as the performance of the whole air conditioning system, during four different thermal load conditions. It is based on the IPLV calculation method, but it also takes into account other factors such as the expected operating hours and weather data (Pérez-Lombard et al., 2011; Zheng et al., 2019).

During the 1960s, the concept of variable air volume systems was introduced to help reduce the energy consumption of a building during its partial load. This type of system is more cost-effective than variable refrigerant flow systems. It also offers a variety of design and control options to meet the needs of different air distribution systems. A typical variable-speed air conditioning system uses a frequency inverter to control the motor's rotation in order to provide the appropriate amount of air to each zone. This

type of system also features an airside economizing function, which allows it to provide cooling when the weather conditions are favorable (Delavari et al., 2020).

The reduction in energy consumption of systems that have constant air volume is mainly due to the reduction in the amount of air that passes through the coils to cool them. This is the main factor that determines the system's overall performance. Large buildings are commonly equipped with a type of central air conditioning system that is powered by a Centrifugal chiller. This type of system's capacity is controlled by the amount of refrigerant that's required to be displaced. In addition to this, a variable speed drive or pre-rotational vanes can also be used to control the system's capacity (Xing et al., 2013).

1.1 study problem

As companies look to improve the efficiency of their air conditioning systems, they're developing new technology that's designed to use less energy. This new type of system, known as a variable refrigerant flow, was first introduced in Japan during the 1980s. This type of system uses a combination of electronic expansion valves and a variable speed compressor to control the flow of refrigerant. It can be connected to an outdoor unit through a refrigeration circuit. There is currently a wide range of VRF types available on the market. A heat pump VRF system uses a combination of heat pump and a heat recovery VRF system to provide both heating and cooling at the same time. The outdoor unit can either be water-cooled or air-cooled. The main component of a VRF system is a scroll compressor. The advantages of this type of system are its compact size and flexibility, as well as its ability to provide a high degree of comfort. (Zheng et al., 2019)

In Egypt, the adoption of variable-speed air conditioning systems is increasing due to their energy-efficient features. The increasing number of commercial establishments that are looking to improve their energy efficiency is also driving the growth of the global market for VRF systems. In Europe and Asia, the adoption of VRF air conditioning systems is also growing. In Japan, approximately 50% of commercial buildings and 33% of large buildings use the system. In the European Union, there is a growing demand for retrofit opportunities that are related to the lack of air conditioning in existing buildings.

Despite the growing popularity of VRF air conditioning systems in the US, manufacturers are still looking for joint ventures or partnerships with American companies (Pérez-Lombard et al., 2011). The increasing number of computational simulations being conducted on the design and operation of air conditioning systems has been instrumental in the development of studies on the efficiency of this type of system. These programs are used in collaboration with other sustainable development initiatives, such as building labeling programs in Egypt.

1.2 study objective

The goal of this paper is to review the latest developments in cooling technology and identify strategies that can help lower the system's kW-R ton from 0.9 to 0.6. It also covers the energy efficiency of

various components. These innovations can provide practical solutions and address specific needs. The paper reviews the latest developments in air conditioning systems and discusses strategies that can help reduce the system's energy consumption. In addition, it explores the development of intelligent air control techniques.

1.3 study methodology

This paper reviews the latest innovations in cooling technology and discusses strategies that could help lower the cooling system's kW/R ton from its current level of 0.9 to 0.6. The paper is divided into three sections, and the first one focuses on the energy efficiency of the devices at the component level.

2. VAV system

The rise of heat exposure is one of the main effects of climate change, according to the Intergovernmental Panel on Climate Change (IPCC). There is also evidence of negative effects of environmental heat on health. Although heat exposure is a major concern in subtropical and tropical climates, it is also a risk factor for mortality in higher-than-normal temperatures. Some studies have shown that in hotter regions, such as the Mediterranean, heatwaves can lead to deaths (Hurnik, 2016).

Urban heat exposure is a particular issue in large cities due to the phenomenon known as the UHI effect. Also, areas with high population growth and urbanization are more prone to experiencing hot climates. In order to protect individuals from heat exposure and reduce their stress levels, air conditioning is commonly used. This type of system can provide comfort and prevent people from experiencing health problems related to heat exposure (Yan et al., 2019).

Despite the various advantages of air conditioning, it is still important to consider the social, material, and discursive aspects of this type of system. In (Randazzo et al., 2020) analyzed the various problems that emerged when the widespread use of AC was first introduced. He criticized the approach taken by some researchers who believe that AC is the most effective solution to prevent heat exposure. Other research such as those conducted by Anderson and Bell, Bouchama, and Whitman also found that this type of system is not beneficial.

Recent studies on the performance of VRF systems have been conducted. These models are available in various online platforms such as EnergyPro, eQuest, and Trace700. In 2020, studies on the simulation of the different configurations of VRF systems have been carried out in EnergyPlus. These studies focused on the air-cooled, water-cooled, and heat recovery systems. (A et al., 2020; Delavari et al., 2020)

In addition, field studies have been carried out to evaluate the effectiveness of VRF systems. In 2018, EnergyPlus released the first version of its software that used a validated system curve-based model for modeling VRF systems. (Li & Jeong, 2018; Lundgren-Kownacki et al., 2018)

The results of the 2018 study on the validated VRF model were compared with those of a 2008 study conducted by Zhou and colleagues. In 2019, a second model based on the physics was released as

part of EnergyPlus' version 8.4. This model, which is known as the VRF-FluidTCtrl, was validated by Hong and colleagues (Ng et al., 2019).

According to studies, the advantages of VRF systems over VAV systems are their lower energy consumption and better partial load efficiency. In 2019, a study was conducted on the cooling efficiency of an office building in Shanghai. The researchers found that the air-cooled systems could reduce the energy consumption of the building by up to 22% (Lundgren & Kjellstrom, 2013).

In 2019, a study was conducted on a building using a VRF system and found that it operated for about 80% of the time (Zheng et al., 2019). In 2017, another study was carried out on the same building and found that the air-cooled system was more energy-efficient than the water-cooled one (Pang et al., 2017).

The study revealed that the energy consumption of a VRF system was significantly lower than that of a VAV system during June and July. In 2011, (Yuan et al., 2011) conducted a similar study in three different office buildings in Maryland, USA.

A third study conducted in 2016 revealed that the energy consumption of a VRF system was between 27.1% and 57.9% of that of a central VAV system. The study was conducted on five office buildings in China. The researchers used site surveys and field measurements to analyze the operation of the systems (Zheng Yang et al., 2016).

In a study conducted in 2017, the researchers discovered that VRF systems are more energy-efficient than a VAV system when it comes to operating in 16 US climate zones. The researchers noted that the energy savings of the systems vary depending on the climate zone. The energy savings of VRF systems are higher in mild and hot climates as opposed to cold regions due to their heating energy consumption. According to the studies, the acceptable system design combination ratio (CR) for VRF equipment is the ratio of the indoor units' capacity to that of the outdoor units (Ma et al., 2017).

3. climate change effect on cooling energy

In 2002, it was estimated that about 33% of global greenhouse gas emissions were caused by buildings. The rising concern about the use of energy has become a major issue in the global community. The IPCC has been instrumental in disseminating information about the effects of climate change on the environment. Its reports have also highlighted the importance of understanding the building energy use characteristics. Although most buildings are expected to have long lifespans, it is still important to understand how they will respond to climate change and its effects on their energy consumption. Climate change is known to have a significant effect on the cooling energy requirements of buildings. In this section, the study will discuss the various factors that have been identified as contributing to this issue (Li & Jeong, 2018).

(Randazzo et al., 2020) modeled the energy demand of residential buildings in different regions around the world in response to climate change. They found that the residential sector's energy consumption for air conditioning would increase significantly over the 2000 to 2100 period. In 2000, it

was estimated that the global energy consumption for air conditioning would reach about 300 TW h. By 2050, it is expected that the consumption of this energy will reach 4,000 TW h.

Based on their study, the energy demand of residential buildings in South Asia could increase by about 50% as a result of climate change. In (Cho et al., 2015) noted that various studies in the US revealed that the energy requirements of commercial buildings could increase due to climate change.

In the US, studies revealed that the energy consumption of commercial buildings is less affected by climate change than that of residential buildings. For instance, in 1995, Rosenthal and colleagues found that the energy consumption of residential buildings increased by 20% as a result of global temperature increases. On the other hand, commercial buildings' energy consumption went up by only 15%. Scott and colleagues noted that the energy requirements of commercial establishments could increase by about 9.4 to 15% per 1 C. On the other hand, for residential customers, the energy consumption of this sector could go up by 12 to 20% per 1 C. In 2006, Huang noted that the cooling energy consumption of buildings could increase by 17% in 2020 as a result of a 1.7 degree Celsius temperature increase (Lundgren & Kjellstrom, 2013; Yan et al., 2019).

Building energy models indicated that the energy consumption of cooling systems would increase by about 10% to 15%. In 2006, Huang looked into the cooling energy consumption of houses under different climate change scenarios. Through his study, he was able to gain a deeper understanding of how climate change would affect the energy usage of buildings in the US by 2020.

In New Orleans and Miami, for instance, the cooling energy consumption of single-family houses was expected to go up by about 20%. In the US, regions such as San Francisco, Chicago, and Boston were expected to see a significant increase in their cooling energy usage. A different study conducted in Switzerland revealed that the country's climate change could cause the annual cooling energy consumption of commercial establishments to increase by about 20%. He noted that the internal heat gains of office buildings could increase by up to 50%.

In Australia, a study conducted by Wang and colleagues looked into the effects of climate change on the energy consumption of residential houses in different regional climates. They utilized key regions such as Darwin, Alice Springs, Hobart, Melbourne, and Sydney to study the varying climate conditions. The researchers found that the energy requirements of residential houses in different climate conditions were higher than those of commercial establishments. For instance, in a warm or hot climate, such as in Alice Springs, the energy requirements of cooling systems were more than those of heating systems (Lundgren & Kjellstrom, 2013).

The researchers (Lundgren-Kownacki et al., 2018; Naves et al., 2021) noted that the annual energy requirement of new residential houses would increase from 61% to 103% by 2050 and then to 112–150% by 2100. One interesting aspect of the study is that houses with higher energy star ratings would not experience an absolute increase in their energy requirement. However, the researchers noted that the energy requirements of houses in different climate conditions were higher than those of commercial

establishments. For instance, in Sydney, the energy requirements of a seven-star house are expected to increase by up to 120%.

Several studies have been conducted on the cooling energy consumption of residential buildings in subtropical climates(Li & Jeong, 2018; Naves et al., 2021). In one study, the researchers noted that under the effects of climate change, the annual cooling load of houses in these regions would increase from 6.1 to 9.8 percent from 2009 to 2100(Lundgren & Kjellstrom, 2013). The researchers came up with a number of pragmatic mitigation strategies that can help improve the energy efficiency of buildings. These include increasing the indoor temperature, using double glazing, and installing thermal insulation. They noted that this method can be easily applied to both new and existing buildings.

4. Innovative air conditioning system designs

4.1 Energy efficient systems

The objective of improving ventilation and developing more energy-efficient building HVAC systems is to develop and demonstrate pragmatic solutions that can provide high-quality ventilation while also promoting better health.

High occupancy spaces are typically the most energy-consuming areas in a building, and ventilation is a vital component of this process. It is therefore important that the design of ventilation systems is geared toward improving their energy efficiency and ensuring that the air quality is good. There are many factors that come into play when it comes to providing adequate ventilation to people and buildings, and it is clear that a lack of ventilation can have detrimental effects on their health. This is why it is important that the government and private sectors work together to develop and promote energy-efficient systems(Kim et al., 2020).

This section looks at some of the latest smart and novel ventilation devices and systems that are designed to provide a holistic solution. Numerous studies have been conducted on the link between ventilation rates and various health outcomes, such as respiratory illnesses, sick building syndrome, and absence rates. Some studies have also used indoor CO₂ concentrations to determine the effect of ventilation on the perceived air quality. Most of these studies found that the lower the ventilation rate, the worse the health outcomes(Davis & Gertler, 2015).

There has been a lot of research indicating that decreasing ventilation rates below 20 CFM per Occupant can have detrimental effectsas showed in figure 1. Studies also suggest that increasing rates above 20 CFM can help improve the health of occupants. In the new-age era, it is important that the design of air conditioning systems accounts for the quality of the indoor air. Besides being energy-efficient, ventilation design should also consider minimizing the potential health effects of air borne illnesses(Cheng Jung Yang et al., 2019).

A recent study revealed that it is feasible for HVAC systems to consider designing systems that can improve their energy efficiency and air quality. The method utilized in this study defines a control strategy

that can be used to manage the outdoor air quality in buildings. The study was conducted on a multivariable and monovariable model. This strategy can help VAV systems identify potential faults. It can also reduce the introduction of other harmful pollutants into the air (Xue et al., 2020).

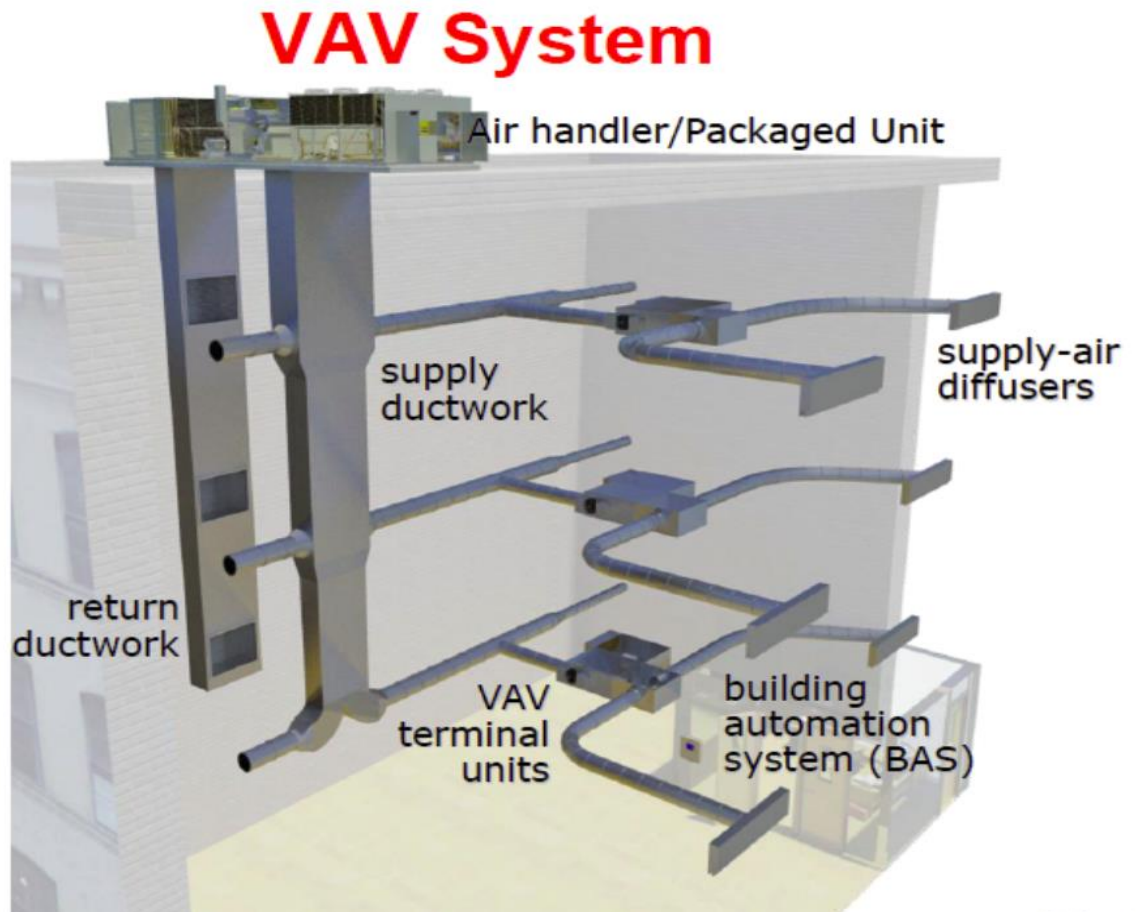

Figure 1 VAV system

The study conducted by Zhang et al. analyzed the effects of different types of ventilation on the energy performance of buildings. They were divided into three categories: stratum, displacement, and mixing. The results indicated that the former performed better than the latter when it came to reducing the transmission loads and improving the efficiency of the building.

The energy savings that can be achieved by implementing this strategy can be substantial. For instance, it can reduce the annual energy consumption of a building by around 25%. A study was conducted in China to analyze the energy efficiency of a variable-air-side economizer system. It was divided into two types of systems: a temperature-based cycle and a enthalpy-based system. The study was conducted in an office building that was exposed to six typical Chinese weather conditions as showed in figure2 (Lee & Tsai, 2020).

The researchers discovered that air economizers perform better in outdoor environments with hot and humid climates than in climates with dry and cold weather conditions. The study revealed that the higher the indoor set-point temperature, the better the performance of the two air-economizer systems. When combined with demand control, this strategy can be considered an energy-efficient and

reliable method. A study was conducted in two schools in Norway with DCDV-CO₂. During daytime operation, the system was able to reduce the air volume by 75% as compared to the CAV. The implementation of the DCDV-CO₂ system during the daytime was able to reduce the building's energy consumption by up to 21%. In addition, the system was able to reduce the unrecovered heat in the ventilation air by 54%(Monteiro et al., 2020).

An optimal air-conditioning system design can be carried out in different zones by implementing model-based strategies that involve the total energy consumption, indoor air quality, and thermal comfort. The first strategy focuses on optimizing the flow rate of fresh air. The strategy involves using the fresh air from the ventilation zones based on their occupancy. Another method is to optimize the temperature control of the critical zones. This will help reduce the overall fresh air intake from the outdoors and improve the building's energy efficiency(Cho et al., 2015).

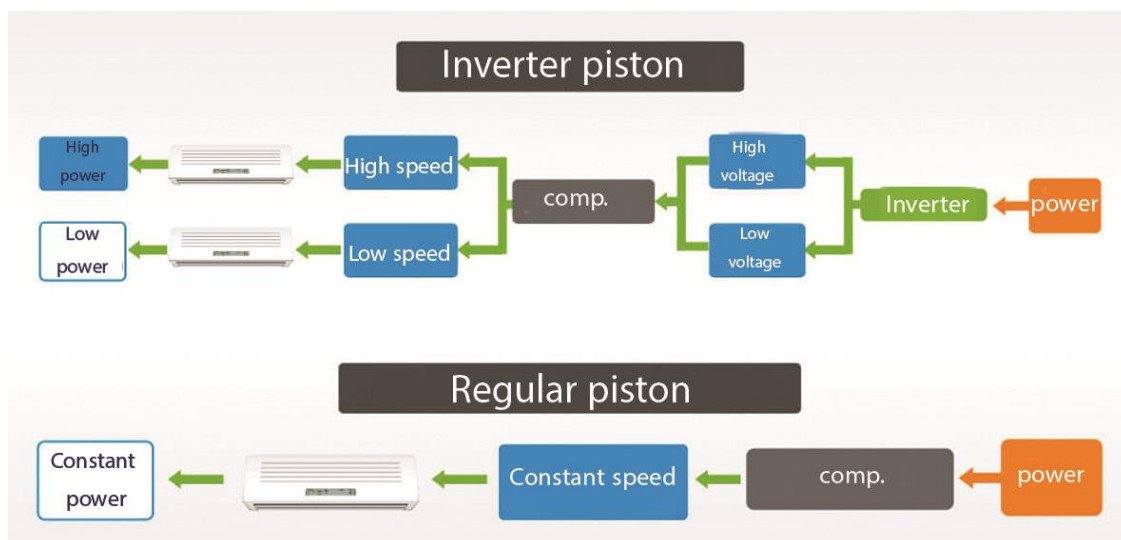

Figure 2 Inverter technology saves energy by up to 50%.

The second strategy is based on a cost function that takes into account the thermal comfort, total energy consumption, and indoor air quality. The third strategy uses a genetic algorithm to improve the temperature set point in critical zones. Through the integration of these three strategies, a building can achieve an optimal thermal comfort and environmental impact. The control system for variable-air-conditioning systems commonly has multi-control loops. When multiple control loops are working at the same time, they can affect each other. In order to minimize the interference between these control loops, Wang and Wang have designed a compensation unit that is designed to provide a decoupling effect(Piselli et al., 2020).

The results of the experiments revealed that the combined effect of the genetic algorithm and the feed-through compensation resulted in a significant improvement in the performance of a variable-air system. The various factors that affect the performance of a building's ventilation system are interrelated. These include the energy consumption of the system, the effects of ventilation on the people, and the lack of proper ventilation in classrooms. It is therefore important that the building's ventilation system is equipped with highly energy-efficient equipment.

4.2 Energy efficient dehumidification systems

A standard imported air conditioner can work in both winter and summer conditions. In many tropical countries, the average annual relative humidity is around 85%. In hot and humid climates, air-conditioning can handle both the latent and sensible loads of cooling space. The proper dehumidification and cooling of air are necessary to ensure the comfort of people. In most cases, the removal of both the sensible and latent heat loads is accomplished through the flow of moist air and the interaction with a cooling coil (Xue et al., 2020).

The surface temperature of a cooling coil is very important in determining the energy consumption of a unit. Raising this temperature can significantly reduce the unit's energy consumption. Another method of reducing the cooling energy is by removing moisture from the air using desiccants. Although there are various forms of energy that can be used to regenerate the desiccant, the reduction in energy consumption by this process over that of refrigeration is more significant. In this section, the study will talk about the latest advances in air dehumidification technology.

A theoretical study was conducted on the design and performance of a solid desiccant that can be used as a working desiccant in an air dehumidification system. The components used for the study included spherical silica gel particles with an average diameter of 3 millimeters. According to studies, the dehumidification period for a hollow-shaped bed can be extended to 15 minutes with a diameter ratio of 7.2. This period can increase with the passage of less air flow rates and the smaller diameter of the bed (Xue et al., 2020).

The results of the study revealed that the bed's adsorption capacity increased during short operation periods. This study allowed the design engineer to determine the optimal energy consumption of the system. In the past few years, the use of liquid-desiccant has been widely used as a dehumidification method that can use less energy. Due to the emergence of new energy-efficient systems, the conventional mode of dehumidification has been modified.

A hybrid air conditioner that incorporates liquid lithium chloride for dehumidification has shown a significant improvement in its performance when compared to other systems. In another study, researchers have found that combining calcium nitrate and calcium chloride solutions in various weight combinations can improve the performance of the system. The results of the study indicated that when a mixture of 20% calcium nitrate and 50% water chloride was mixed, the desiccant produced a higher vapor pressure depression than that of other solutions. The vapor pressures achieved by this mixture at various temperatures were 14.7, 20, 6, 34.4, and 48.3.

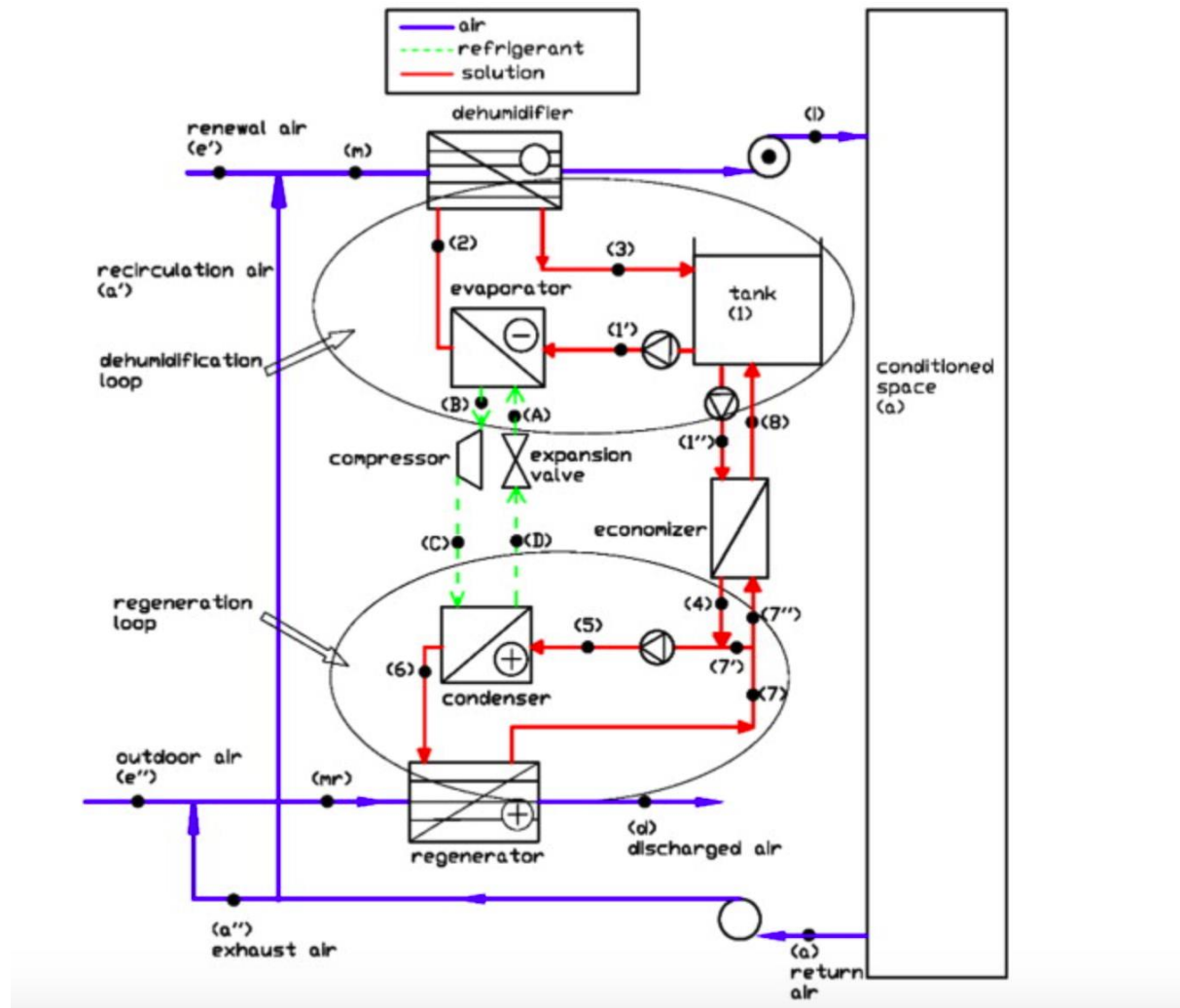

Figure 3 A hybrid air-conditioning system

Results and discussion

A properly functioning air conditioning system can help maintain the comfort levels of people in their homes and workplaces, especially when it's hot and humid. In addition to cooling, air conditioning also dehumidifies the air in a building. In tropical climates, where the energy consumption of buildings is higher than 50%, air-conditioning, ventilation, and heating can account for more than 50% of total building energy usage. This is mainly due to the heavy duty cooling technologies that are used to remove both latent and sensible heat loads. Today's modern chiller plants are equipped with various components, such as compressors, cooling towers, pumps, and fans. These components work together to provide a cooling effect to a building (A et al., 2020; Xue et al., 2020).

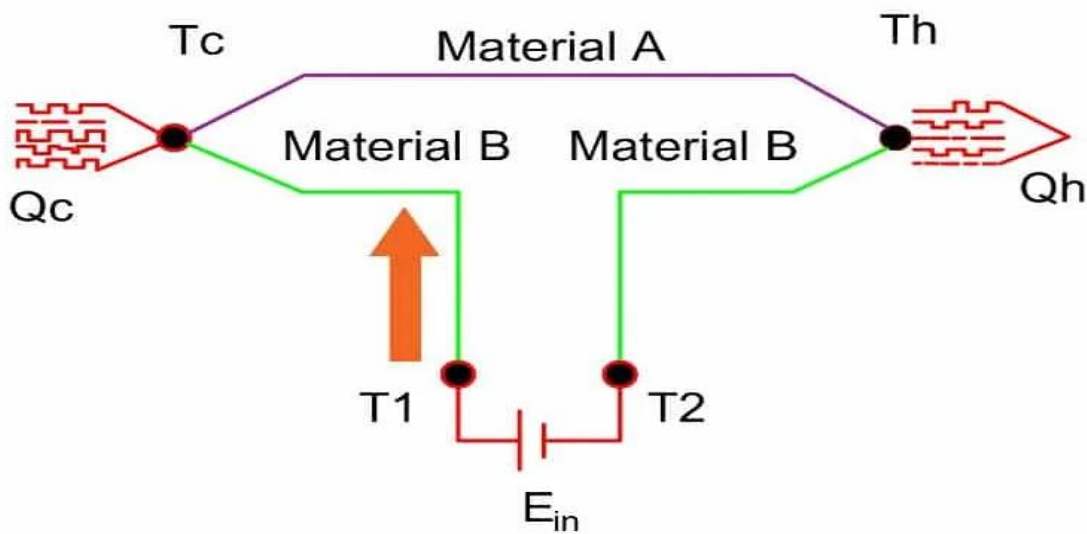

Figure 4 Thermoelectric Cooling

The various components of an air conditioning system are mainly responsible for their energy usage. When it comes to monitoring the cooling efficiency of a plant, two levels of monitoring are involved. One is the efficiency of the equipment, such as the chillers and the compressors, and the other is the overall efficiency of the plant's cooling towers and other components. A holistic approach to optimizing a cooling plant's energy usage can help achieve a low energy input. This can be achieved through the use of various components and techniques (Andrade et al., 2021; Pérez-Lombard et al., 2011).

This paper presents a review of the latest innovations in the cooling industry that could help lower the energy consumption of a cooling system by up to 0.6 kW/R ton. The paper also explores the various strategies and technologies that are designed to enhance the efficiency of a cooling system's components. This paper reviews the latest innovations in air conditioning systems that can help reduce their energy consumption. It also explores the development of smart chiller sequencing techniques and intelligent air control strategies. The paper presents an overview of the various innovations that have been developed to help improve the efficiency of air conditioning systems. Some of these have been extensively studied and are currently being used on a larger scale.

Conclusion

A comprehensive review of the literature on the various aspects of cooling technologies and their energy-efficient applications has been conducted. The findings of this study are used to identify the main advantages of these systems and their control methods. Through the literature review, the study were able to show how various efforts have been made to improve the energy efficiency of air conditioning. For instance, through the use of dehumidification, it has been observed that the energy efficiency of air conditioning has been increased by 33%. On the other hand, through the use of better compression technology, it has been observed that the COP has been improved by 20%. In addition to these, intelligent air flow control methods can also help improve IAQ. One of the most important factors that can contribute

to the reduction of energy consumption in cooling systems is the effective dehumidification process. This process can help remove the moisture of air from the air. According to a study, a liquid-based dehumidification system that combines lithium chloride with an air conditioning system can improve the COP values by up to 20%.

In this paper, the study discuss the various types of renewable energy-assisted air-conditioning systems that are designed to provide cooling. These systems are capable of feeding waste heat as a fuel for their operation. From a practical perspective, these types of systems can excel when there is a readily available supply of high-grade waste heat. In sunny and hot climates, solar energy can also be a good source of heat. When a cooling system is integrated with a prime-mover, it can create a trigeneration or cogeneration system. This type of system can be regulated in order to meet the specific needs of its users. In addition to producing more than one vital output, such systems can also realize a combined electrical and thermal efficiency of more than 70%.

This article presents promising methods that can help improve the energy efficiency of air conditioning. Some of these include the use of intelligent air flow control strategies and the development of smart sequencing of chiller operations. These systems can reportedly achieve a performance improvement of up to 0.75 kW/ton. Due to the increasing number of innovations in the field of cooling technology, it is important to keep in mind that there is no single strategy or technology that can achieve the lowest energy consumption per R ton. Instead, a combination of various strategies and technologies is often needed.

A holistic approach is needed to reach new energy-efficient targets. This can be achieved by considering the plant's needs and practicality. Although some of the innovations presented in this article are still in their early stages of development, the study believe that they will eventually be used instead of traditional systems. These strategies and technologies can help reduce the energy consumption of air conditioning units and improve the comfort levels of people living in urban areas.

References

- A, Mona Subramaniam, Jain, Tushar, & Yamé, Joseph J. (2020). Bilinear model-based diagnosis of lock-in-place failures of variable-air-volume HVAC systems of multizone buildings. *Journal of Building Engineering*, 28. <https://doi.org/10.1016/j.jobe.2019.101023>
- Andrade, Ángel, Restrepo, Álvaro, & Tibaquirá, Juan E. (2021). EER or Fcsp: A performance analysis of fixed and variable air conditioning at different cooling thermal conditions. *Energy Reports*, 7. <https://doi.org/10.1016/j.egy.2020.12.041>
- C. Munaaim, M. Arkam, Al-Obaidi, Karam M., & Azizul Abd Rahim, M. (2017). Performance comparison of solar assisted and inverter air conditioning systems in Malaysia. *Journal of Design and Built Environment*, 17. <https://doi.org/10.22452/jdbe.sp2017no1.5>
- Cho, Jin-Kyun, Moon, Jung-Hwan, Rhee, Kyu-Nam, & Kang, Ho-Suk. (2015). Energy Consumption Characteristics of Patient Room HVAC Systems for Large Hospital Buildings in Worldwide Climate Zones. *Journal of the Architectural Institute of Korea Planning & Design*, 31(3). https://doi.org/10.5659/jaik_pd.2015.31.3.171

- Davis, Lucas W., & Gertler, Paul J. (2015). Contribution of air conditioning adoption to future energy use under global warming. *Proceedings of the National Academy of Sciences of the United States of America*, 112(19). <https://doi.org/10.1073/pnas.1423558112>
- Delavari, Abolfazl, Ghassabi, Ghodrat, & Saffarian, Mohammad Reza. (2020). Numerical and experimental investigation of the effect of air conditioning duct on the room temperature distribution and energy efficiency. *Journal of the Brazilian Society of Mechanical Sciences and Engineering*, 42(1). <https://doi.org/10.1007/s40430-019-2133-9>
- Hurnik, Maria. (2016). Novel cylindrical induction controller and its application in VAV air conditioning system in an office building. *Energy and Buildings*, 130. <https://doi.org/10.1016/j.enbuild.2016.08.074>
- Kim, Sunghak, Choi, Inchul, Kim, Dohyeong, & Lee, Minho. (2020). Deep neural network based ambient airflow control through spatial learning. *Electronics (Switzerland)*, 9(4). <https://doi.org/10.3390/electronics9040591>
- Lee, Dasheng, & Tsai, Fu Po. (2020). Air conditioning energy saving from cloud-based artificial intelligence: Case study of a split-type air conditioner. *Energies*, 13(8). <https://doi.org/10.3390/en13082001>
- Li, Shiyang, & Jeong, Jae Weon. (2018). Energy performance of liquid desiccant and evaporative cooling-assisted 100% outdoor air systems under various climatic conditions. *Energies*, 11(6). <https://doi.org/10.3390/en11061377>
- Lundgren, Karin, & Kjellstrom, Tord. (2013). Sustainability challenges from climate change and air conditioning use in urban areas. In *Sustainability (Switzerland)* (Vol. 5, Issue 7). <https://doi.org/10.3390/su5073116>
- Lundgren-Kownacki, Karin, Hornyanszky, Elisabeth Dalholm, Chu, Tuan Anh, Olsson, Johanna Alkan, & Becker, Per. (2018). Challenges of using air conditioning in an increasingly hot climate. *International Journal of Biometeorology*, 62(3). <https://doi.org/10.1007/s00484-017-1493-z>
- Ma, Yunlong, Saha, Suvash C., Miller, Wendy, & Guan, Lisa. (2017). Comparison of different solar-assisted air conditioning systems for Australian office buildings. *Energies*, 10(10). <https://doi.org/10.3390/en10101463>
- Monteiro, Suzane A., Monteiro, Flávia P., Tostes, Maria E. L., & Carvalho, Carminda M. (2020). Methodology for Energy Efficiency on Lighting and Air Conditioning Systems in Buildings Using a Multi-Objective Optimization Algorithm. *Energies*, 13(13). <https://doi.org/10.3390/en13133303>
- Naves, Alex Ximenes, Esteller, Laureano Jiménez, Haddad, Assed Naked, & Boer, Dieter. (2021). Targeting energy efficiency through air conditioning operational modes for residential buildings in tropical climates, assisted by solar energy and thermal energy storage. Case study Brazil. *Sustainability (Switzerland)*, 13(22). <https://doi.org/10.3390/su132212831>
- Ng, Kim Choon, Shahzad, Muhammad Wakil, Burhan, Muhammad, & Oh, Seung Jin. (2019). Approaches to energy efficiency in air conditioning: Innovative processes and thermodynamics. *Energy Procedia*, 158. <https://doi.org/10.1016/j.egypro.2019.01.349>
- Ni, Jiacheng, & Bai, Xuelian. (2017). A review of air conditioning energy performance in data centers. In *Renewable and Sustainable Energy Reviews* (Vol. 67). <https://doi.org/10.1016/j.rser.2016.09.050>
- Pang, Xiufeng, Piette, Mary A., & Zhou, Nan. (2017). Characterizing variations in variable air volume system controls. *Energy and Buildings*, 135. <https://doi.org/10.1016/j.enbuild.2016.11.031>
- Pérez-Lombard, Luis, Ortiz, José, Coronel, Juan F., & Maestre, Ismael R. (2011). A review of HVAC systems requirements in building energy regulations. In *Energy and Buildings* (Vol. 43, Issues 2–3). <https://doi.org/10.1016/j.enbuild.2010.10.025>
- Piselli, Cristina, di Grazia, Matteo, & Pisello, Anna Laura. (2020). Combined effect of outdoor microclimate boundary conditions on air conditioning system's efficiency and building energy demand in net zero energy settlements. *Sustainability (Switzerland)*, 12(15). <https://doi.org/10.3390/su12156056>

- Randazzo, Teresa, de Cian, Enrica, & Mistry, Malcolm N. (2020). Air conditioning and electricity expenditure: The role of climate in temperate countries. *Economic Modelling*, 90. <https://doi.org/10.1016/j.econmod.2020.05.001>
- Xing, Rong, Rao, Yuxiang, TeGrotenhuis, Ward, Canfield, Nathan, Zheng, Feng, Winiarski, David W., & Liu, Wei. (2013). Advanced thin zeolite/metal flat sheet membrane for energy efficient air dehumidification and conditioning. *Chemical Engineering Science*, 104. <https://doi.org/10.1016/j.ces.2013.08.061>
- Xue, Yucong, Zhao, Kang, Qian, Yidong, & Ge, Jian. (2020). Improved operating strategy for air-conditioning systems based on the indoor occupancy rate. *Journal of Building Engineering*, 29. <https://doi.org/10.1016/j.jobee.2020.101196>
- Yan, Xiuying, Liu, Cong, Li, Meili, Hou, Ating, Fan, Kaixing, & Meng, Qinglong. (2019). Climate compensation and indoor temperature optimal measuring point energy saving control in VAV air-conditioning system. *Energies*, 12(22). <https://doi.org/10.3390/en12224398>
- Yang, Cheng Jung, Yang, Tzu Chun, Chen, Po Tuan, & David Huang, K. (2019). An innovative design of regional air conditioning to increase automobile cabin energy efficiency. *Energies*, 12(12). <https://doi.org/10.3390/en12122352>
- Yang, Zheng, Ghahramani, Ali, & Becerik-Gerber, Burcin. (2016). Building occupancy diversity and HVAC (heating, ventilation, and air conditioning) system energy efficiency. *Energy*, 109. <https://doi.org/10.1016/j.energy.2016.04.099>
- Yuan, Qiuxia, Ma, Yitai, Liu, Chuntao, Dai, Baomin, & Yan, Qihui. (2011). Thermodynamic perfectibility based analysis of energy-efficiency standards for air conditioning products in China. *Energy and Buildings*, 43(12). <https://doi.org/10.1016/j.enbuild.2011.09.035>
- Zheng, Lin, Zhang, Wei, Xie, Lingzhi, Wang, Wei, Tian, Hao, & Chen, Mo. (2019). Experimental study on the thermal performance of solar air conditioning system with MEPCM cooling storage. *International Journal of Low-Carbon Technologies*, 14(1). <https://doi.org/10.1093/ijlct/cty062>